



Corporate Sales Presentation

Philosophy

To maintain a Total Quality Management System, premised on the following criteria.

1. Providing products and services that meet our customers well-defined need, use or purpose.
2. Satisfying customers' expectations.
3. Complying with our customers' standards and specifications.
4. Providing products and services at a competitive price.
5. Gradual and orderly improvement and growth.

Introduction

Kenosha Metal Products, Inc. is a manufacturing corporation that produces metal stampings and small assemblies.

Through internal growth founded on superior quality, delivery, price and technical support, Kenosha Metal Products has established itself as a preferred supplier to the automotive industry.

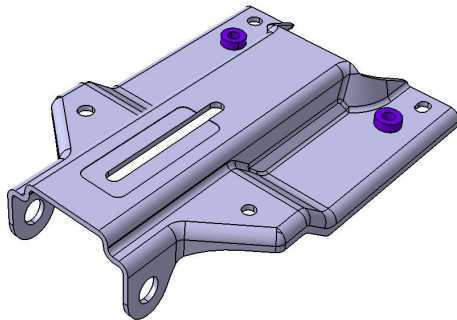

Established in 1960

Manufacturing Facility

Pleasant Prairie, WI (70,500 Sq FT)

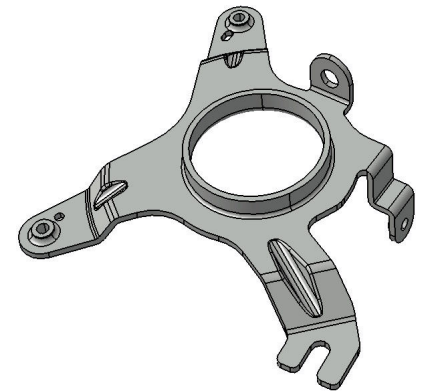

Operational

Three Shifts

Equipment and Capabilities



9 Presses – Progressive, Programmable cams, Electronic Die Protection

Press Capacity:

(3) 85 ton OBI presses

(1) 88 ton OBI press

(1) 121 ton OBI press

(1) 440 ton Straight Side

(1) 165 ton OBS press

(1) 176 ton “2 point” OBS press

(1) 275 ton “2 point” OBS press

Equipment and Capabilities

Automated Tilt Lever Assembly
Work Center

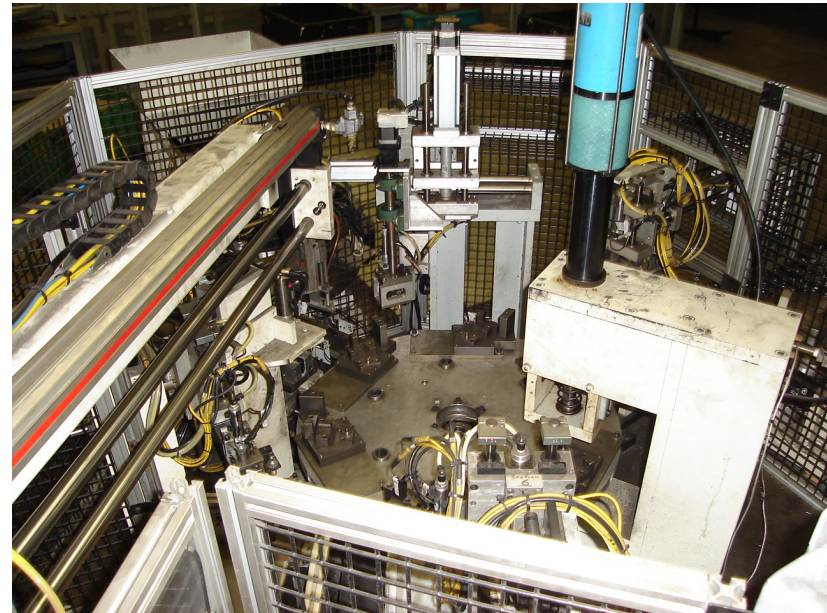
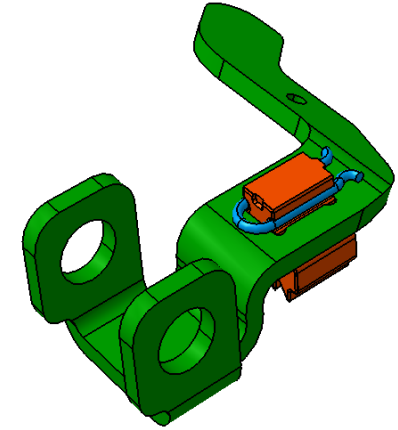

Capabilities and Equipment

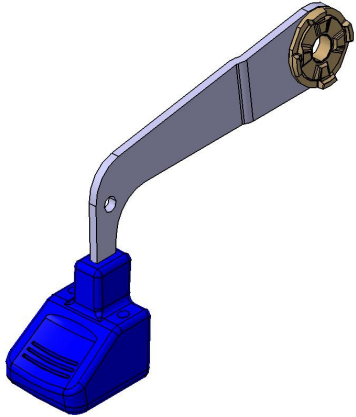

**Flexible
Automated Assembly
Work Center**

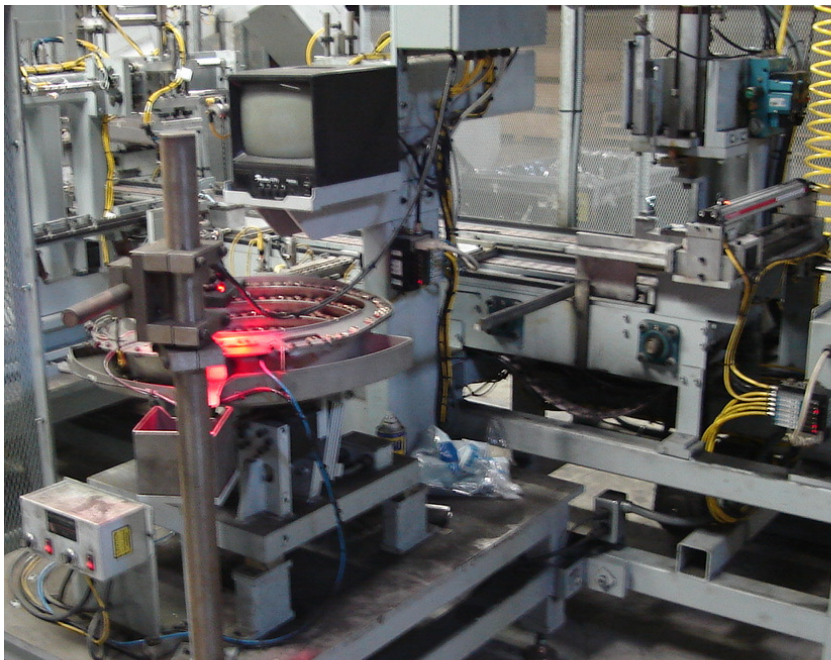

On Site Capabilities

Full Program Management

Product Design

Software

CATIA : Two seats (V5)

AutoCAD: One seat

Cadkey: One seat

EDI: Fully capable of ASN Transmission, Build Schedules
and Shipment Schedules

Technology

In-Die Tapping and Staking capability (i.e. Clinch Screws and Nuts).

- Minimizes or eliminates secondary operations
- Reduces costs
- Enhances quality

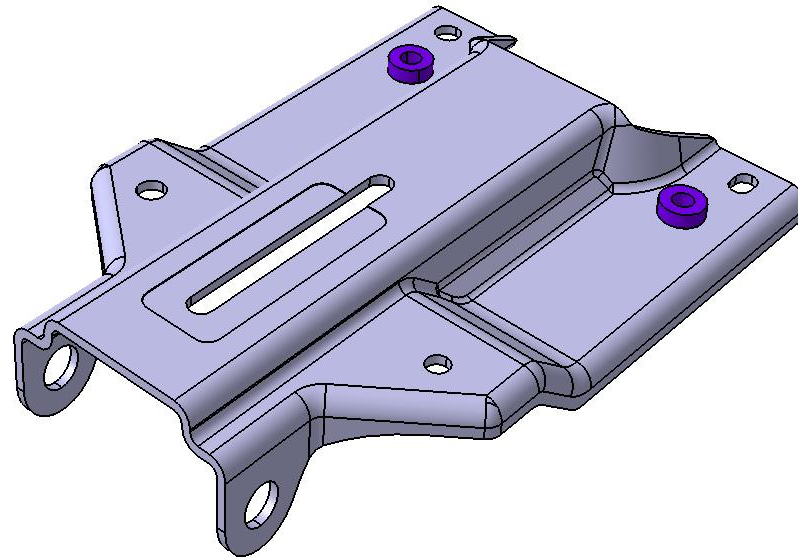

Tooling Maintenance

All tooling is maintained internally (3 shifts).



Quality Systems



ISO 9001:2008

Registration date:
11/7/2007

Registrar: NQA, USA

Customer Base & Corresponding Markets

NSK

TOYOTA

Tilt Lever Assemblies,
 Telescope Lever Assemblies,
 Energy Absorption Brackets,
 and Key Lock Collars.

HONDA

Pivot Brackets, Tilt Brackets,
 and Inner Brackets

NISSAN

Tilt Lever Assemblies,
 Telescope Lever Assemblies,
 and Mounting Brackets

FORD/MAZDA

Tilt Lever Assemblies,
 Telescope Lever Assemblies,
 Energy Absorption Brackets,
 Over Brackets, and Key Lock
 Collars

MERCEDES

Pivot Brackets, and Reach and
 Rake Plates

YOROZU

Front Suspension Components

MSC

Akebono

Quite Steel®
 Brake Shims

Federal Mogul

Nisshinbo

America Friction Technologies

TMD – Mexico

FIAT / CHRYSLER

Engine Component Mounting
 Brackets, Internal Engine and
 Transmission Parts,
 Suspension Components,
 Interior Trim Attachment
 Brackets, etc.

ATF, Inc.

DELPHI / AUTO LIV

CONTINENTAL

BROSE

Airbag Mounting Components
 Brake Input Rods
 Seat Spindle Adjuster

AISIN HOLDINGS OF AMERICA

Electrical Mounting
 Components

POLLMANN N.A.

Sun Roof Components

UFI FILTERS

Fuel Filters Assemblies

CTS of CANADA

Mounting Brackets